



Air Torque Actuated Ball Valves

Features & Benefits

- Oasis provides the Air Torque Actuated Ball Valve to ensure seamless supply of the complete package
- Floating drive dog for vibration dampening - extending life of stem & stem hole.
- Sturdy rigid stainless steel construction.
- Supplied with Air Torque Actuators (www.airtorque.com).



Applications

- Compressor Blow-down.
- Dispenser sequencing.
- Isolation.
- Priority Panels.
- Storage.
- Mobile Storage & transport trailers.

Materials

PART CODE	DESCRIPTION	MATERIAL
BV700 series	Ball Valves	As per product specification
Actuator	All materials specified CNG excellent	As per manufacturers specification
BVAC	Actuator mount bracket	All T304 Stainless Steel Drive dog and bolts all stainless steel*

*T316 Stainless steel available on request.



Air Torque Actuated Ball Valves

Application & Specification Information

Operating pressure as per valve.

NPT is standard quoted thread. SAE, BSP available or as per customer request.

All Oasis products are manufactured to ISO 9001:2000 accredited standards.

Pricing includes drive dog, bracket, valve & actuator supplied ready to mount or kitset.

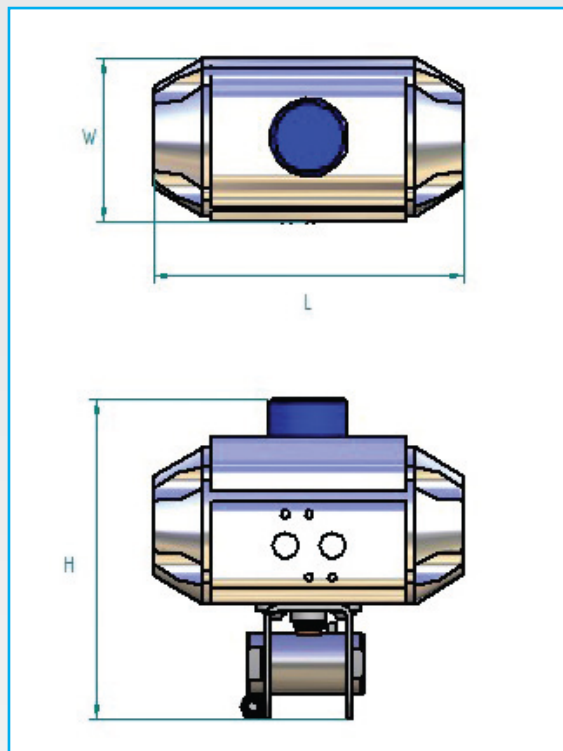

Dimensions

Item Code	Nominal Ball Valve Bore	Valve Operating Pressure	Actuator Code**	Actuator Connect	Air (Activating Gas) Pressure required	Dimension maximum (mm)		
	Inch	Bar (psi)			Bar	H	L	W
BV703-4N6SDDN-0134	3/8"	420 (6000)	Air Torque AT101	1/4"NPT Namur	6	144	158.5	83
BV704-4N6SDDN-0146	1/2"	420 (6000)	Air Torque AT201	1/4"NPT Namur	6	168	210.5	94.5
SBV706-4N6SDDN-0148	3/4"	420 (6000)	Air Torque AT251	1/4"NPT Namur	6	230	247.5	106.3
SBV708-4N6SDDN-014A	1"	420 (6000)	Air Torque AT301	1/4"NPT Namur	6	253	268.5	123

** Other actuator options available on request.